

Traversenmontage Instruction with Traverse Montage avec Traverse Montaggio di Traverse Montaje de Traverse Montagem de Traverse Montage van de Traverse Montaż trawersu

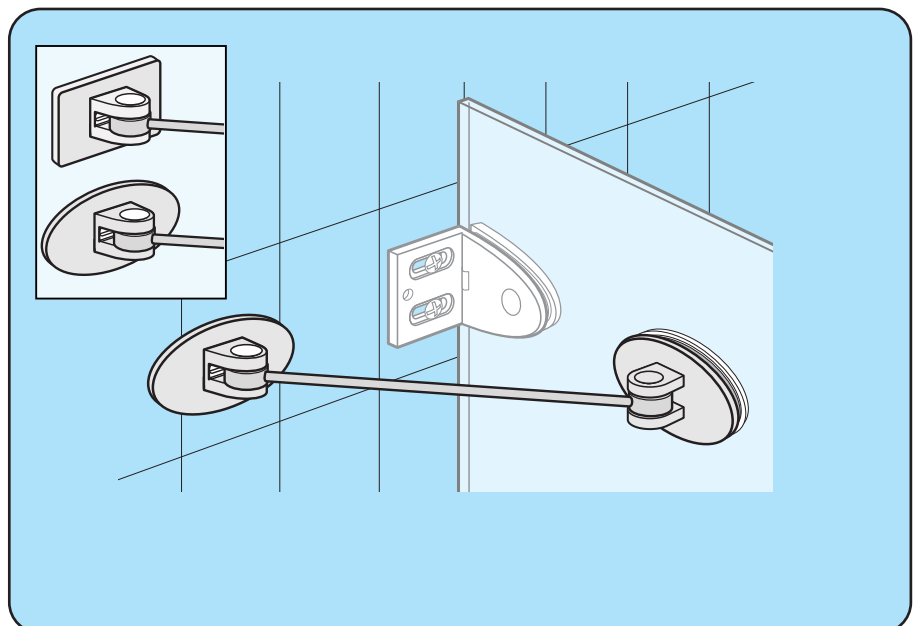

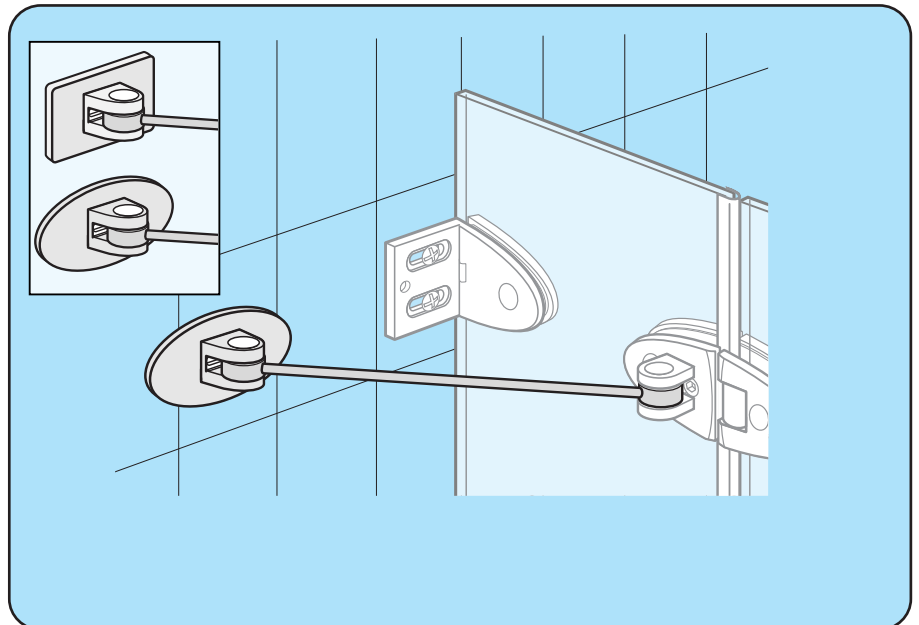

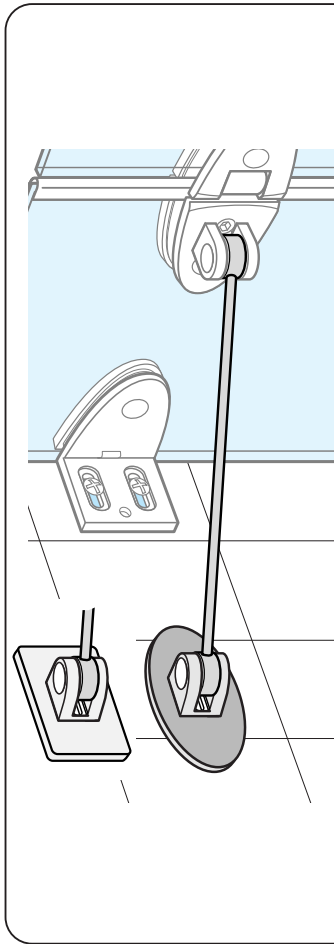



- D Achtung:** Vor der Montage Produkte auf Transportschäden untersuchen. Für Schäden an bereits montierten Produkten kann keine Haftung übernommen werden.
- GB Warning:** Examine all items for damage which may have been caused in transit before starting installation work. No liability can be accepted once items have been installed. This product must be fitted onto tiled walls.
- F Attention:** Avant le montage, contrôler si le produit n'a pas subi dommage pendant le transport. Aucune responsabilité ne pourra être assumée pour des produits déjà montés.
- I Attenzione:** Prima del montaggio verificare che il prodotto non abbia subito danni di trasporto. Per danni a prodotti già montati non si assumono responsabilità.
- E Atención:** Antes de la instalación, revisen el producto respecto a posibles daños de transporte. No podemos responder de los daños una vez instalado el producto.
- P Atenção:** Antes de la instalação, verifique o produto para detectar possíveis danos de transporte. Não nos responsabilizamos por danos uma vez instalado o produto.
- NL Attentie:** Controleer het product op transportschade alvorens het te monteren. Voor schade aan reeds gemonteerde delen kan geen aansprakelijkheid aanvaard worden.
- PL Uwaga:** Przed montażem produkt musi być sprawdzony pod kątem uszkodzeń transportowych. Uszkodzenia zgłoszone po zamontowaniu nie mogą być podstawą reklamacji.

- D**
Achtung! Tragfähigkeit der Wand beurteilen: Siehe technische Information in der Montageanleitung. **Montageanleitung für den Fachhandwerker!** Montageanleitung nach erfolgter Montage dem Endkunden übergeben.
- GB**
Warning! Assess the load capacity of the wall: See technical information within the installation instructions. **Assembly instructions for skilled tradesmen!** Pass the installation instructions on to the customer after assembly.
- F**
Attention! Déterminer la résistance du mur: veuillez vous reporter aux informations techniques des instructions de montage. **Notice de montage pour l'artisan spécialisé!** Remettre cette notice de montage au client final une fois le montage effectué.
- I**
Attenzione! Verificare la portata del muro: vedere le informazioni tecniche contenute nelle istruzioni di montaggio. **Istruzioni di assemblaggio per esercenti specializzati!** Dopo l'assemblaggio, inoltrare le relative istruzioni al cliente.
- E**
Atención! Valorar la capacidad de soporte de la pared: ver información técnica en la instrucción de montaje. **Manual de montaje para el trabajador especializado!** Devolución del manual al cliente tras el montaje.
- P**
Atenção! Valorar la capacidad de soporte de la pared: consultar as informações técnicas nas instruções de montagem. **Manual de Montagem para o trabalhador especializado!** Devolução do Manual de Montagem ao cliente, após a realização da montagem.
- NL**
Attentie! Sterkte van de wand beoordelen: Zie de technische informatie in de montagehandleiding. **Montagehandleiding voor de installateur!** Na de installatie deze montagehandleiding aan de klant geven. Hierin staan de bestelnummers voor reserveonderdelen.
- PL**
Uwaga! Sprawdzić nośność ścian: patrz informacja wewnątrz instrukcji montażu. **Instrukcja montażu dla instalatora!** Po zamontowaniu instrukcję montażu proszę przekazać klientowi końcowemu.





Verpackungsinhalt Contenu de l'emballage Contenido del embalaje Verpakkingeninhoud
 Package content Contenu imballo Conteúdo da embalagem Zawartość opakowania







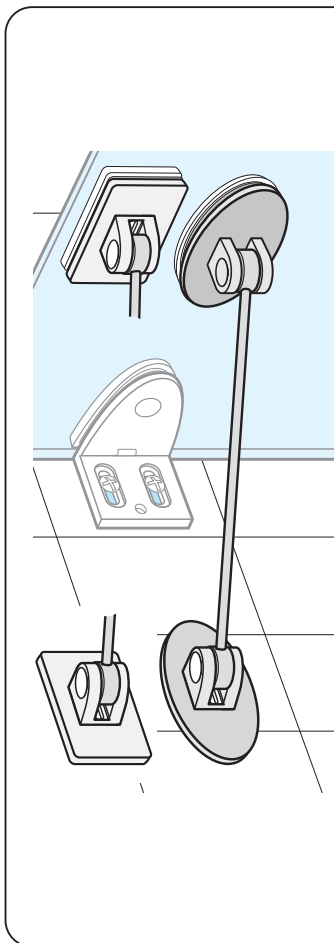
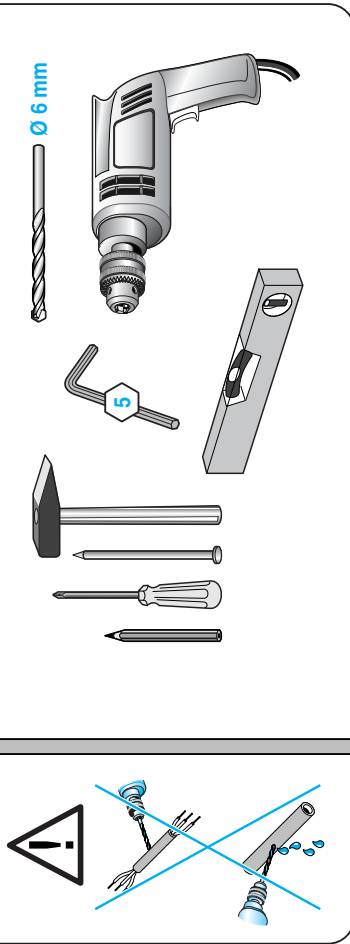

	4 x 50 1 x 600265		300297 - 265 mm 300309 - 330 mm 1 x		M6 x 20 2 x 600205
	SX 6x 30 1 x 251050		1 x 230294		1 x 311175
	2 x 230717		1 x 230453		

Benötigtes Werkzeug (nicht enthalten)
 Necessary tools (not included)
 Outil Nécessaire (non fourni)
 Attrezzature necessaria (non inclusa)

Herramientas necesarias (no incluidas)
 Ferramentas necessarias (não incluidas)
 Gereedschap (niet ingesloten)
 Niezbędne narzędzia (nie zawarte w opakowaniu)



Verpackungsinhalt Contenu de l'emballage Contenido del embalaje Verpakkingeninhoud
 Package content Contenu imballo Conteúdo da embalagem Zawartość opakowania

	4 x 50 1 x 600265		300297 - 265 mm 300309 - 330 mm 1 x		M6 x 12 1 x 601098
	SX 6x 30 1 x 251050		1 x 230294		1 x 230198 (251034)
	2 x 230717		2 x 600205		2 x 311175 (251034)

Benötigtes Werkzeug (nicht enthalten)
 Necessary tools (not included)
 Outil Nécessaire (non fourni)
 Attrezzature necessaria (non inclusa)

Herramientas necesarias (no incluidas)
 Ferramentas necessarias (não incluidas)
 Gereedschap (niet ingesloten)
 Niezbędne narzędzia (nie zawarte w opakowaniu)

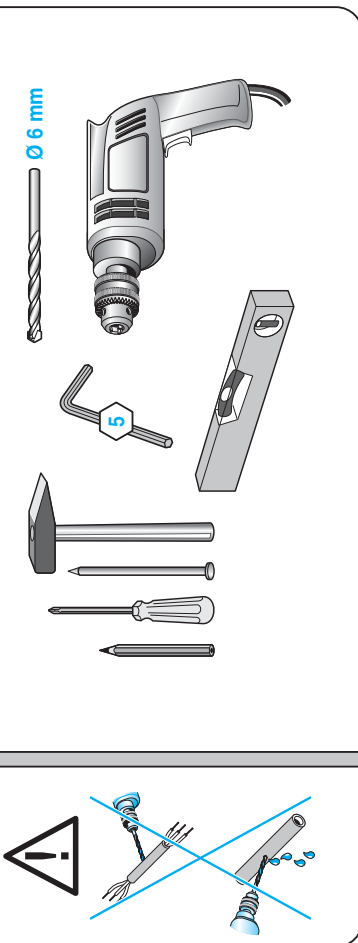

1

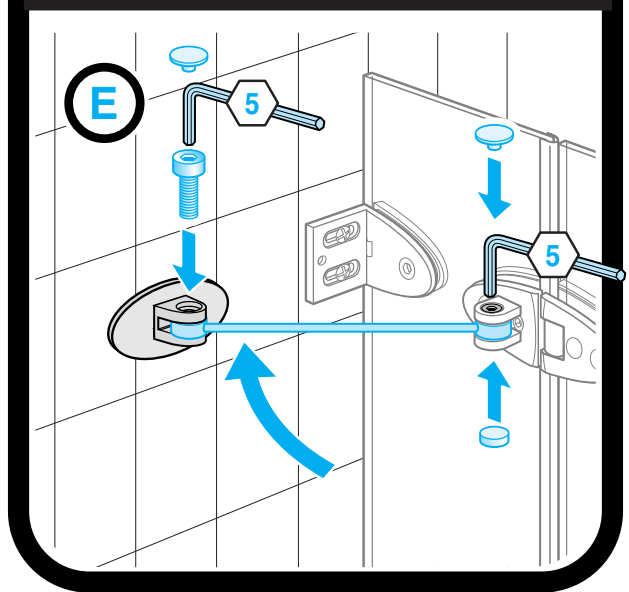
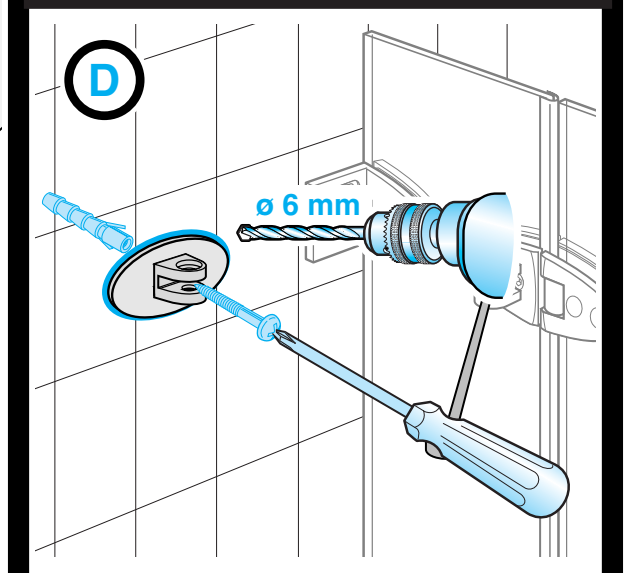
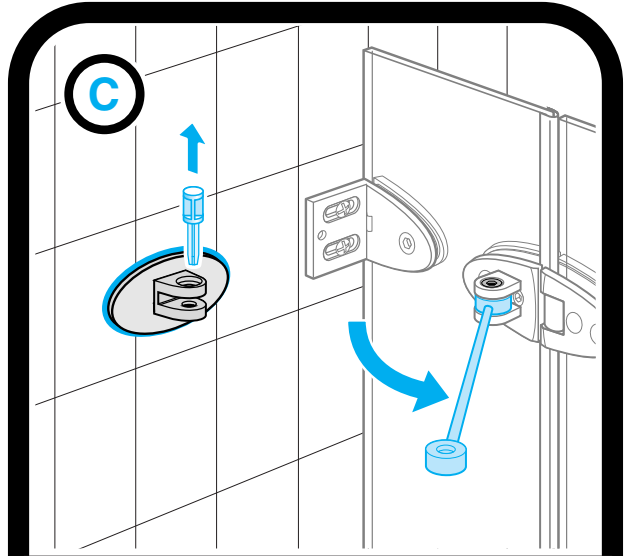
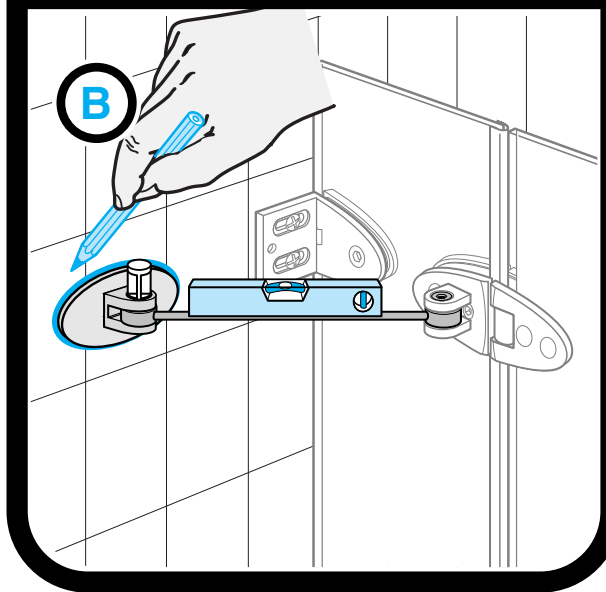
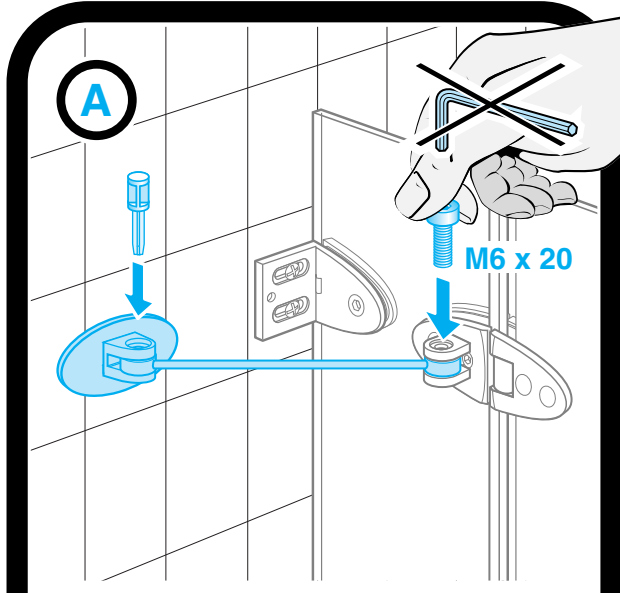
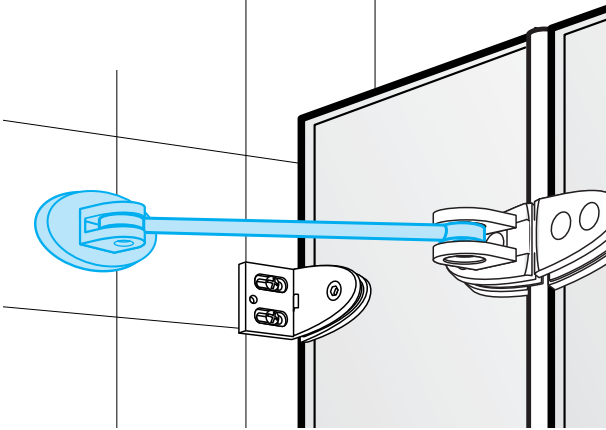

2

